



CABINET PARTS SECTION

READING A PARTS LIST

- I. **ITEM NUMBER** is found in two locations:
 - A. It is on the drawing plate, and identifies the part and its location;
 - B. The same number is in the parts lists and ties the two together.

- II. **PART NUMBER** is the part number that has been assigned to a specific part by SandenVendo America, Inc., for easier identification.

- III. **QUANTITY REQUIRED** relates to the amount required of a part, or will be indicated by "A/R" (as required) to attach it to another part.

- IV. **PART NAME AND DESCRIPTION** is the general description for the part, for easier identification when ordering a like part.

- V. **HARDWARE** is identified by a letter in a hexagon. Refer to hardware list section or description and part numbers. See pages C-3 and C-4.

The example below will show how the parts are listed in the parts lists:

1. **VEND MOTOR ASSEMBLY:** This is the main assembly name, and any replaceable parts will be indented below the assembly.

2. **RETAINER CAM:** This is an individual part, and will be indented. These indented parts can be ordered separately, so you do not need to order the entire assembly.













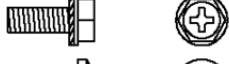

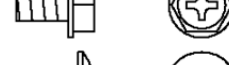

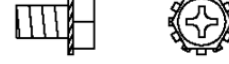
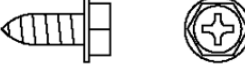
3. Whenever an assembly is ordered, all the parts that are indented will be included in the assembly. Any hardware will be listed next to their corresponding parts.



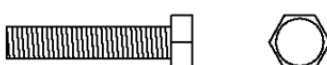



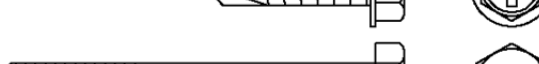
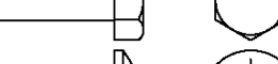





















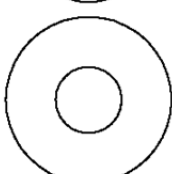

4. Any parts that may be ordered separately will not have any indented parts listed below them.

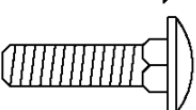
ITEM NO	DESCRIPTION	QTY REQ	PART NO.
1	VEND MOTOR ASSEMBLY	~	1115821
2	RETAINER CAM	1	1113244
3	TIMING CAM	1	1113236

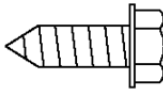
If an asterisk is listed below the parts list, it is an indication that special information is noted. There may be more than one asterisk (*) (**) (***) denoting special notes.

HARDWARE LIST

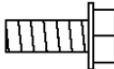
PART NO.	DESCRIPTION	PICTORIAL
A	V800762 #8 X 5/16" TAPPING SCREW	
B	V802139 #8 X 5/8" TAPPING SCREW	
C	V800586 #8 X 3/8" TAPPING SCREW W / LOCK WASHER	
D	V802214 #8 X 1/2" TAPPING SCREW (FOR PLASTIC)	
E	V801475 #8 X 1/2" TAPPING SCREW	
F	V801421 #10 X 5/16" TAPPING SCREW	
G	V802212 #10 X 3/8" TAPPING SCREW	
H	V802047 #10 X 5/16" TAPPING SCREW W / LOCK WASHER	
I	V802141 #10 X 1/2" TAPPING SCREW	
J	V801422 #10 X 1/2" TAPPING SCREW	
K	V801489 #10 X 1/2" SELF DRILLING SCREW	
L	V800512 #10 X 1-3/8" TAPPING SCREW	
M	V802115 #10 X 1" BOLT	
N	V801360 1/4" X 1/2" TAPPING SCREW W / LOCK WASHER	
O	V801343 1/4" X 1" TAPPING SCREW	
P	V801490 1/4" X 1" SELF DRILLING SCREW	
Q	V802053 1/4" X 2-1/4" BOLT	
R	V802069 1/4" X 5/8" CARRIAGE BOLT	
S	V801434 1/4" X 3/4" CARRIAGE BOLT	

T	V800267	1/4" X 3/8" BOLT		
U	V800956	#8 NUT W / LOCK WASHER		
V	V800952	#10 NUT W / LOCK WASHER		
W	V802111	#10 HEX NUT		
X	V802113	#10 LOCK NUT W / NYLON INSERT		
Y	V800959	1/4" NUT W / LOCK WASHER		
Z	387925	1/4" LOCK NUT W / NYLON INSERT		
AA	V802062	3/8" LOCK NUT W / NYLON INSERT		
AB	V801013	#10 FLAT WASHER		
AC	389026	#10 FLAT WASHER, LARGER O.D.		
AD	V801491	3/8" FLAT WASHER		
AE	V801412	1/8" POP RIVET		
AF	V801435	1/4" 20 X 1" CARRIAGE BOLT		
AG	V802220	1/4" X 3/4" TAPPING SCREW		
AH	1123719	SPACER		
AI	V801422	#10 X 1/2" TAPPING SCREW		

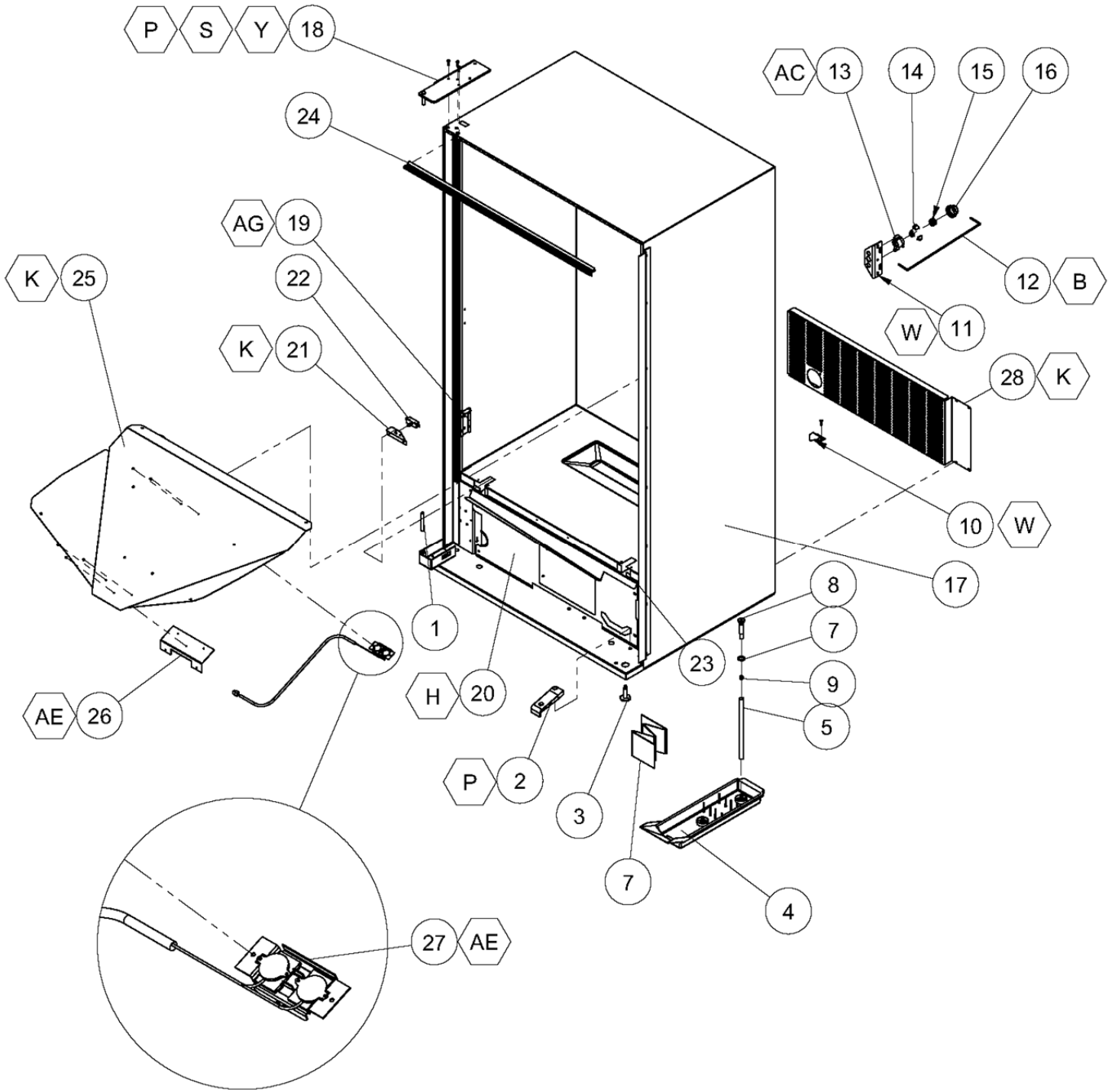

CABINET ASSEMBLY

ITEM NO.	DESCRIPTION	QTY REQ	PART NO. (621, 721, 821)
1	HINGE PIN	1	389071
2	RAMP	1	1120387
3	LEVELING LEG	1	1059902
4	CONDENSATE PAN	1	1122475
5	DRAIN TUBE	1	1088449-1
6	FIBERGLASS EVAPORATOR BOARD	1	1122728
7	DRAIN TUBE GASKET	1	387837
8	DRAIN TUBE FUNNEL	1	1068678
9	NUT – DRAIN TUBE	1	387925
10	BRACKET – REFRIGERATION	2	1123527
11	LATCH BRACKET	1	1123675
12	QUICKER LOCK ASSEMBLY	1	1123724
13	NUT RETAINER HOUSING	1	1123689
14	NUT SEGMENT	3	1033085
15	SPRING	1	389690
16	CAP	1	1111988
17**	SIDE DECAL	2	**
18	TOP HINGE	1	2000805-03
19	BRACKET STACK SUPPORT	2	1148205
20	AIR DAM/KICK PANEL ASSEMBLY, 39"	1	1126880
	AIR DAM/KICK PANEL ASSEMBLY, 32"	1	1126880-1
21	DOOR SWITCH BRACKET	1	1126691
22	DOOR SWITCH	1	323007
23	OVERLAPPING DOOR GUARD – 72"	1	2001376
	OVERLAPPING DOOR GUARD – 79"	1	2002325
24	SEAL, 39"	1	1122500
25	VEND CHUTE, 39"	1	1123453
	VEND CHUTE, 32"	1	1123451
26	CHUTE BRACKET	1	1148228
27	DROP SENSOR ASSEMBLY	1	1122923
28	SAFETY SCREEN, 39"	1	1168689
	SAFETY SCREEN, 32"	1	1168707

FOR A COMPLETE LIST OF HARNESSSES, PLEASE SEE PAGE C - 15.

* NOTE: WHEN ORDERING CABINET ASSEMBLY, PLEASE PROVIDE **9-CODE** OR **11-CODE** AND MANUFACTURER'S DATE CODE.

NOTE: WHEN ORDERING DECALS, PLEASE PROVIDE **STYLE.

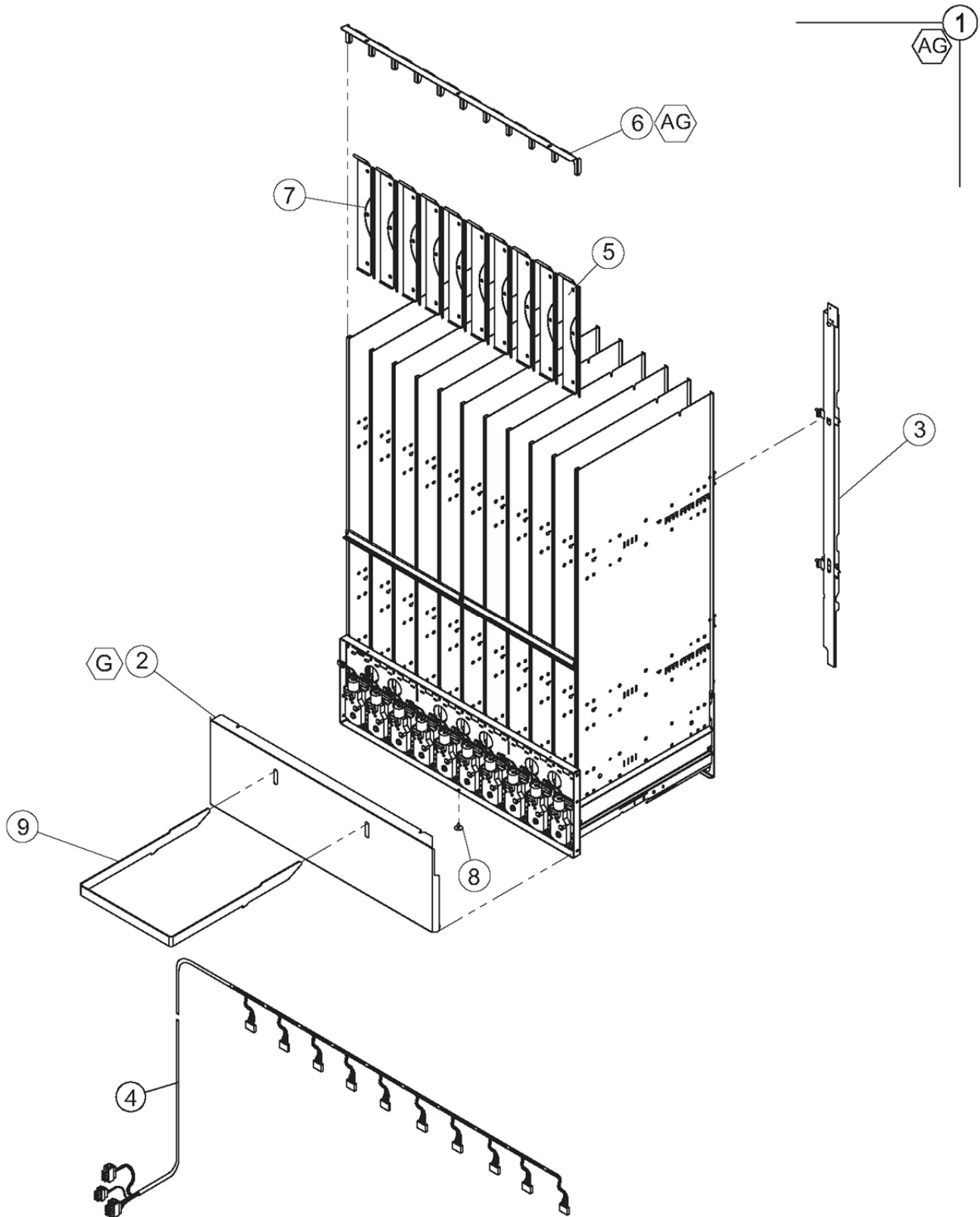

STACK ASSEMBLY

ITEM NO.	MODEL NUMBER		621	721	821
	DESCRIPTION	QTY REQ	PART NO.	PART NO.	PART NO.
1	STACK CHASSIS ASSEMBLY	1	1123591-01	1123591-02	1123591-03
2	MOTOR COVER	1	1123037	1123037	1125116
3	BACK SPACER ASSEMBLY	*	1123047-1	1123047-1	1123047
4	MOTOR HARNESS	1	1123050	1122918	1122918
5	LOWER RETAINER	*	1128242	1148242	1148242
6	TOP STACK STRAP	1	1123039	1122809	1122809
7	FRICTION WIRE	*	1125607	1125607	1125607
8	SNAP IN PLUG	1	V802043	V802043	V802043
9	LOADING RACK	1	1123586	1123586	1123586

FOR A COMPLETE LIST OF HARNESSES, PLEASE SEE PAGE C-15.

*MODELS 721 & 821 USE 10 EACH.
 MODEL 621 USES 8 EACH.

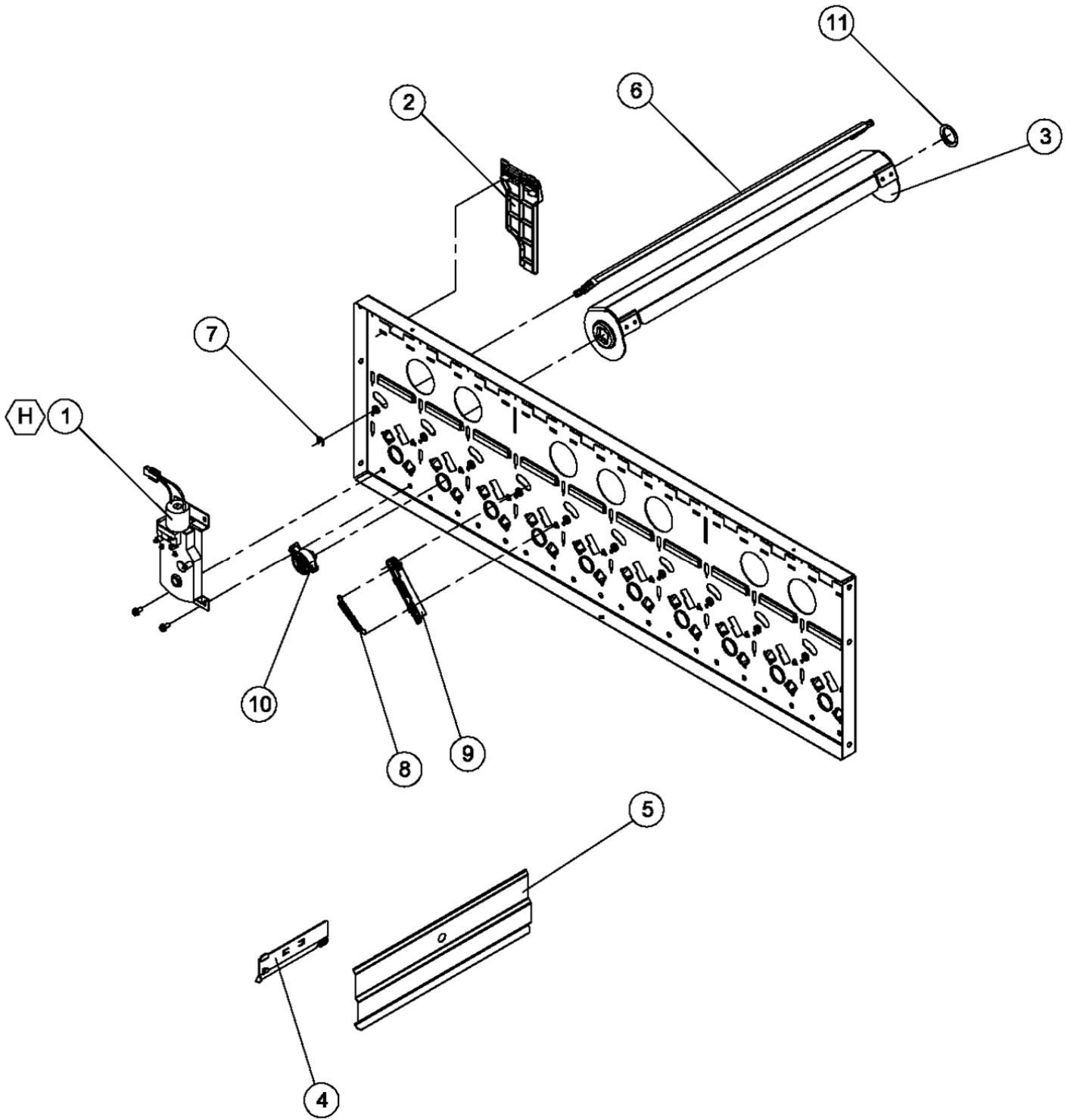

MECH PLATE ASSEMBLY

ITEM NO.	MODEL NUMBER	621		721/821	
	DESCRIPTION	QTY REQ	PART NO.	QTY REQ	PART NO.
1	VEND MOTOR ASSEMBLY	8	1122820	10	1122820
2	FRONT SPACER	8	1122814	10	1122814
3	VEND BUCKET	8	1122815	10	1122815
4	CAN CLIP	8	1122856	10	1122856
5	GATE	8	1122818	10	1122818
6	E-CLIP – GATE	8	V801080	10	V801080
7	SPRING	8	390326	10	390326
8	GATE LINK	8	1122819	10	1122819
9	COUPLING CAM	8	1122817	10	1122817
10	REAR BUSHING	8	1122816	10	1122816

FOR A COMPLETE LIST OF HARNESSSES, PLEASE SEE PAGE C-15.

*DEPENDING ON PRODUCT

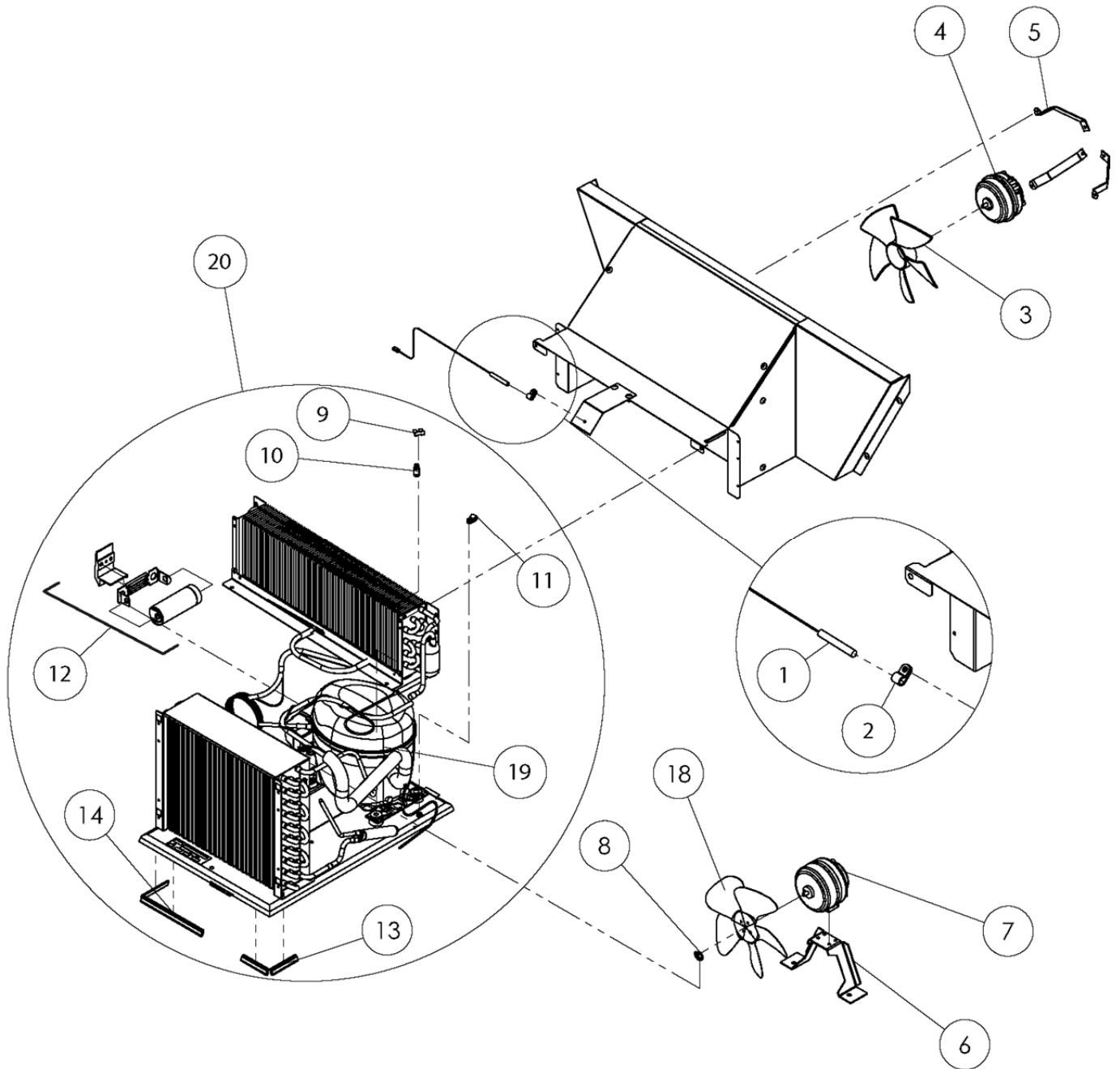

621 / 721 / 821 REFRIGERATION ASSEMBLY

ITEM NO.	DESCRIPTION	QTY REQ	PART NO.
1	TEMPERATURE SENSOR	1	1122924
2	CLAMP, 1/4"	1	324099-2
3	EVAPORATOR FAN BLADE	1	1113562
4	FAN MOTOR – EVAPORATOR	1	42321-17
5	BRACKET – FAN MOTORS	3	1117996
6	CONDENSER FAN MOTOR BRACKET	1	1201656
7	FAN MOTOR – CONDENSER, 115V	1	1121770
8	FAN MOTOR CLIP – CONDENSER	1	V42323
9	CLIP – COMPRESSOR MOUNT	2	343874
10	STUD – COMPRESSOR MOUNT	2	1191032
11	CLAMP, 5/16"	1	324099-3
12	CAPACITOR ASSEMBLY	1	1190994
13	EDGE TRIM – SHORT	3	388304-1
14	EDGE TRIM – LONG	1	388304-3
15	COMPRESSOR POWER HARNESS (NOT PICTURED)	1	1121019-1
16	EVAPORATOR FAN HARNESS (NOT PICTURED)	1	1122193
17	EVAPORATOR POWER HARNESS (NOT PICTURED)	1	1124185
18	CONDENSER FAN BLADE	1	389623
19	ASY COMPRESSOR, EMBRACO, 115V/60H	1	1190208
20	ASY, REFER, CO2, 115VAC 60HZ	1	1185298

FOR A COMPLETE LIST OF HARNESSES, PLEASE SEE PAGE C-15.

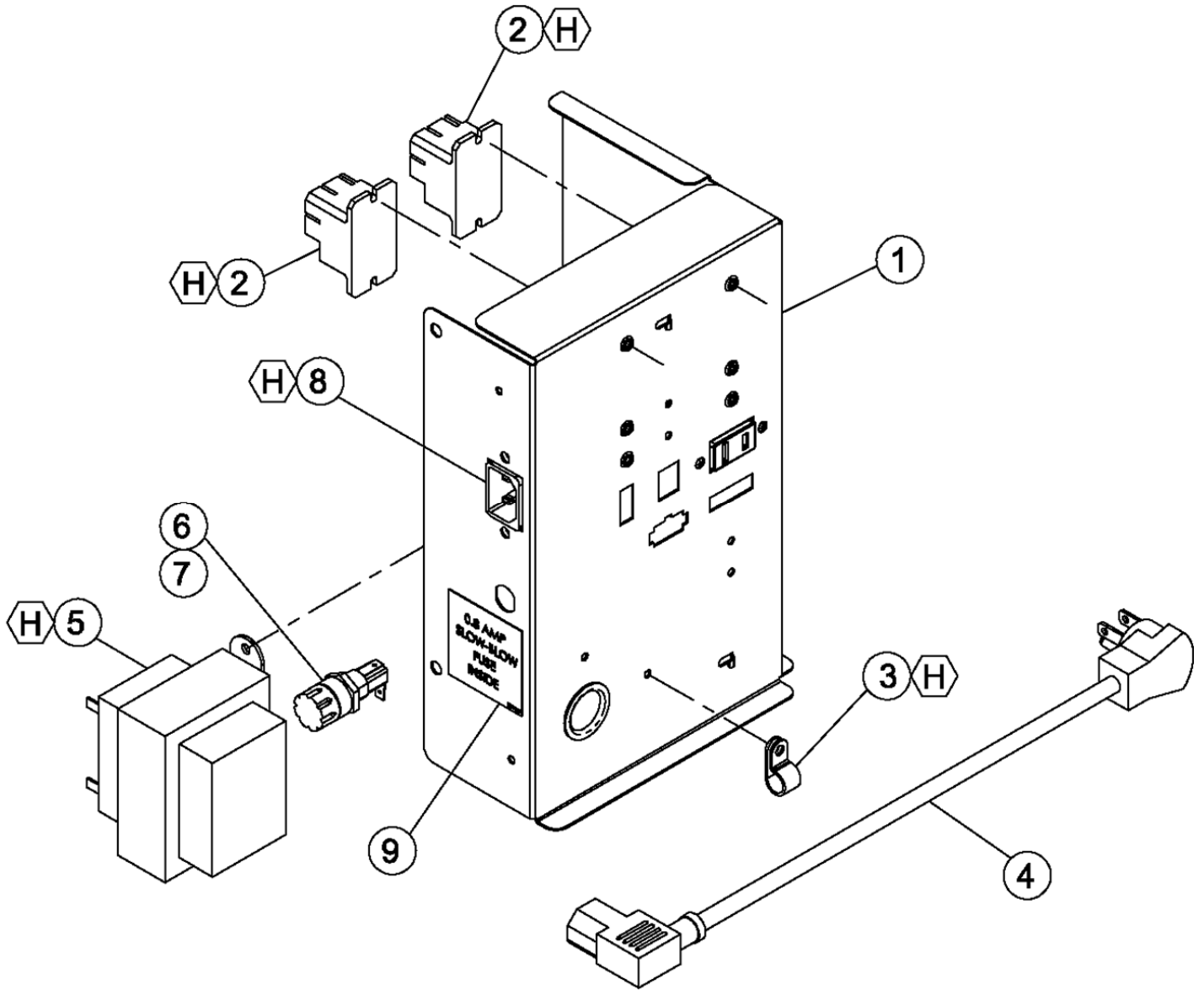

POWER BOX ASSEMBLY

ITEM NO.	DESCRIPTION	QTY REQ	PART NO.
1	POWER BOX HOUSING	1	1148515
2	RELAY	2	1128801
3	CLAMP	1	324099-3
4	CORDSET	1	1184889
5	TRANSFORMER	1	1111201
6	FUSEHOLDER	1	387966
7	0.8 AMP FUSE (NOT SHOWN)	1	1053864
8	POWER HARNESS	1	1123444
9	FUSE LABEL	1	1126640

FOR A COMPLETE LIST OF HARNESSES, PLEASE SEE PAGE C-15.

SandenVendo America, Inc. HARNESS QUICK REFERENCE GUIDE TRADE VENDORS

PART NO.	DESCRIPTION	PURPOSE	621	721	821
1122905	Door Harness	Connects motors, temp. sensors, transformer, drop sensors, and relays to the control board	X	X	X
1111287	Selection Harness – 10 Select	Connects the selection buttons to the control board	N/A	X	X
1117872	Selection Harness – 8 Select	Connects the selection buttons to the control board	X	N/A	N/A
1126164	Display Harness	Connects the display to the control board	X	X	X
1122918	Motor Harness – 10 Select	Connects the vend motors to the door harness	N/A	X	X
1123050	Motor Harness – 8 Select	Connects the vend motors to the door harness	X	N/A	N/A
1122193	Evaporator Fan Harness	Connects the evaporator fans to the power distribution box	X	X	X
1123444	Power Distribution Harness	Input for 110v service cord and output to compressor, evaporator, fans, control board, and transformer	X	X	X
1124065	Motor Harness w/ Pre-cool – 10 Select	Connects the vend motors to the door harness	N/A	X	X
1124066	Motor Harness w/ Pre-cool – 8 Select	Connects the vend motors to the door harness	X	N/A	N/A
1124864	Live Display Lighting Harness	Connects the lights to the control board	X	X	X
1126870	Live Display Selection Harness – 10 Select	Connects the selection buttons to the control board	N/A	X	N/A
1126871	Live Display Selection Harness – 8 Select	Connects the selection buttons to the control board	X	N/A	N/A
1126872	Live Display Read-to-Vend/Soldout Harness	Connects the vend motors to the door harness	X	X	N/A
1124570	MDB Harness	Connects the coinage to the control board	X	X	X